



**Tiekstra Techniek**

Metaalbewerkingsmachines en toebehoren

Wulpstraat 13 - 9363 GK - Marum - Tel 0653734259  
info@tiekstratechniek.nl - www.tiekstratechniek.nl



# MILLING MACHINE

Vertical



**RIGID & PRECISE**



20150130

# MILLING Machine Vertical

## AVAILABLE MILLING HEADS



**VA**  
Step pulley



**VS**  
Mechanical variable



**Vi**  
Inverter variable



## CE SAFETY SPECIFICATION:

### CE SPINDLE SAFETY GUARD

When spindle safety guard is opened, machine power will be cut-off immediately.

**1**

**VA**  
**VS**

3HP motor, 16-Step Spindle Speed  
3HP motor, Variable Spindle Speed

### MACHINE FEATURES:

- All meehanite cast iron machine body.
- Choice of R-8 or NT30 spindle taper.
- New type head housing, Better cutting performance.
- CP4 spindle bearings + heavy-duty long-sleeve spacer installed in between bearings, enhance stable cutting.
- 890 x 230mm table size.
- Axes travels:  
X= 610mm (manual), 560mm (auto)  
Y= 300mm  
Z= 380mm
- 3 axes slideways are hardened and precision ground.
- X, Y-axis slideways are coated with wear-resistance film.

**2**

**VA**  
**VS**  
**Vi**

3HP motor, 16-Step Spindle Speed  
3HP motor, Variable Spindle Speed  
3HP motor, Variable spindle speed controlled by inverter. Electro-magnetic brake for spindle

### MACHINE FEATURES:

- Humpback type machine body for increased rigidity.
- New type head housing, Better cutting performance.
- Choice of NT30 or R-8 spindle taper.
- 1245 x 230mm table size.
- Axes travels:  
X=970mm (manual), 890mm (auto),  
Y=360mm  
Z=355mm
- 3 axes slideways are hardened and precision ground.
- X, Y-axis slideways are coated with wear-resistance film.
- X, Y-axis feed screws are hard chrome plated for maximum wear resistance.
- **2Vi STANDARD ACCESSORIES INCLUDE:**  
Full electrics cabinet, control panel box, coolant system, coolant/chip tray.



New 2V humpback machine body, rigid and stable.

Optional machine back-guard and coolant / chip tray.



Machine Shown With Optional Accessories



Machine Shown With Optional Accessories

# 3



**3HP motor, 16-Step Spindle Speed**  
**3HP motor, Variable Spindle Speed**  
**3HP motor, Variable spindle speed controlled by inverter. Electro-magnetic brake for spindle**

### MACHINE FEATURES:

- Kondia type machine body features heavy-duty.
- Choice of NT30 or R-8 spindle taper.
- New type head housing, Better cutting performance.
- 1372 x 254mm table size.
- Axes travels:  
X=1005mm (manual),  
865mm (auto),  
Y=395mm  
Z=380mm
- Y-axis square slideways.
- 3 axes slideways are hardened and precision ground.
- X, Y-axis slideways are coated with wear-resistance film.
- X, Y-axis feed screws are hard chrome plated for maximum wear resistance.
- **3Vi STANDARD ACCESSORIES INCLUDE:** Full electrics cabinet, control panel box, coolant system, coolant/chip tray.



# 4



**5HP motor, 16-step spindle speed**  
**5HP motor, Variable spindle speed**  
**5HP motor, Variable spindle speed controlled by inverter. Electro-magnetic brake for spindle**

### MACHINE FEATURES:

- Kondia type machine body features heavy-duty.
- NT40 spindle taper.
- New type head housing, Better cutting performance.
- 100mm quill diameter.
- 1372 x 254mm table size.
- Axes travels:  
X=1050mm (manual),  
970mm (auto),  
Y=390mm  
Z=355mm
- Y-axis square slideways.
- 3 axes slideways are hardened and precision ground.
- X, Y-axis slideways are coated with wear-resistance film.
- X, Y-axis feed screws are hard chrome plated for maximum wear resistance.
- **4Vi STANDARD ACCESSORIES INCLUDE:** Full electrics cabinet, control panel box, coolant system, coolant/chip tray.



Machine Shown With Optional Accessories

# 6



- 1 NEW 5HP INVERTER SPINDLE MOTOR + ELECTRO- MAGNETIC BRAKE, MORE POWERFUL AND SAFE OPERATION.**
- 2 AIR POWERED DRAWBAR IS STANDARD EQUIPMENT.**
- 3 NEW TYPE HEAD HOUSING , BETTER CUTTING PERFORMANCE.**
- 4 AUTO LUBE SYSTEM AND HALOGEN WORKLIGHT ARE STANDARD EQUIPMENT.**
- 5 CP4 SPINDLE BEARINGS + HEAVY-DUTY LONG-SLEEVE SPACER INSTALLED IN BETWEEN BEARINGS, ENHANCE STABLE CUTTING.**
- 6 FULL ELECTRICS CABINET + CONTROL PANEL BOX + COOLANT SYSTEM + COOLANT/CHIP TRAY ARE STANDARD EQUIPMENT.**
- 7 Y & Z AXIS SQUARE SLIDEWAYS.**
- 8 CHROMED & HARDENED X / Y / Z AXIS LEADSCREWS WITH DOUBLE NUTS. 3 AXIS SLIDEWAYS ARE HARDENED AND PRECISELY GROUND. X / Y COATED WITH WEAR-RESISTANCE FILM.**
- 9 X & Y AXES ARE DRIVEN BY INVERTER MOTORS, WHILE Z AXIS (KNEE ELEVATING) FITTED WITH RAPID MOTOR.**
- 10 EXTRA LARGE 305 X 1524 MM (12" X 60") WORKTABLE IS HARDENED AND PRECISELY GROUND, TABLE T-SLOTS ARE ALSO PRECISELY GROUND.**
- 11 ALL MEEHANITE CAST IRON MACHINE BODY.**



# MACHINE SPECIFICATIONS

unit / mm

ITEM/MODEL	1VA	1VS	2VA	2VS	2Vi	3VA	3VS	3Vi	4VA	4VS	4Vi	6Vi
<b>TABLE</b>												
Table size	230 x 890 (9" x 35")		230 x 1245 (9" x 49")			254 x 1372 (10" x 54")			305 x 1524 (12" x 60")			
No. of T-slots	NO. 3		NO. 3			NO. 3			NO. 3			
T-slots width	16 (0.63")		28 (1.1")			28 (1.1")			28 (1.1")			
Slideway hardened & surface ground	YES		YES			YES			YES			
Table surface hardened & ground	YES		YES			YES			YES			
Slideway dovetail "V" or square "SQ"	XYZ = V		XYZ = V			XZ = V Y = SQ			X = V YZ = SQ		X = V YZ = SQ	
<b>MANUAL TRAVELS</b>												
X axis	Manual	610 (24.0")	970 (38.2")	1005 (39.6")	1050 (41.3")	850 (31.5")						
	Auto (Opt.)	560 (22.0")	890 (35.0")	865 (34.1")	970 (38.2")	820 (32.3")						
Y axis	300 (11.8")	360 (14.2")	395 (15.6")	390 (15.4")	365 (14.4")							
Z axis	380 (15.0")	355 (14.0")	380 (15.0")	355 (14.0")	360 (14.2")							
Ram	350 (13.8")	470 (18.5")	560 (22.0")	555 (21.9")	560 (22.0")							
<b>MILLING HEAD</b>												
Motor	3HP		3HP			3HP		5HP		5HP		
Spindle speed r.p.m. (Step Pulley)	50HZ / 70-4200 16-Step 60HZ / 80-5440 16-Step		50HZ / 75-3800 16-Step 60HZ / 60-4300 16-Step			N / A						
Spindle speed r.p.m. (Mechanical Variable)	50HZ / Low range 60-420 High range 500-3600-VARIABLE 60HZ / Low range 70-500 High range 600-4200-VARIABLE		50HZ / Low range 75-450 60HZ / Low range 60-500 High range 680-3800-VARIABLE High range 550-4300-VARIABLE			N / A						
Spindle speed r.p.m. (Inverter Variable)	N / A		70-4200-INVERTER									
Spindle taper	R8 / NT30					NT40						
Quill travel	127 (5")											
Quill feed/spindle rev.	0.04, 0.08, 0.15 rev. (0.0015", 0.0031", 0.006")											
Quill diameter	86 (3.38")					100 (4.00")		105 (4.13")				
Head tilt (front or back)	45°											
Head swivel (left or right)	90°											
<b>CONSTRUCTION</b>												
ALL MEEHANITE CAST IRON MACHINE BODY												
Column turret diameter	Ø290 (Ø11.42")		Ø380 (Ø14.96")			Ø380 (Ø14.96")		Ø390 (Ø15.35")		Ø380 (Ø14.96")		
Knee width	255 (10.04")		290 (11.42")			330 (12.99")		340 (13.39")		340 (13.39")		
Column bearing length	335 (13.19")		420 (16.54")			455 (17.91")		430 (16.93")		460 (18.11")		
Saddle / table bearing length	360 (14.17")		505 (19.89")			515 (20.28")		515 (20.28")		860 (33.86")		
Ram / turret bearing length	320 (12.60")		410 (16.14")			440 (17.32")		435 (17.13")		435 (17.13")		
Ram length	530 (20.87")		735 (28.94")			830 (32.68")		850 (33.46")		840 (33.07")		
Machine net weight	640kgs (1410 lbs)		950kgs (2100 lbs)			1350kgs (2985 lbs)		1450kgs (3190 lbs)		1550kgs (3410 lbs)		

• Above specifications are subject to change without prior notice.

# MACHINE DIMENSIONS

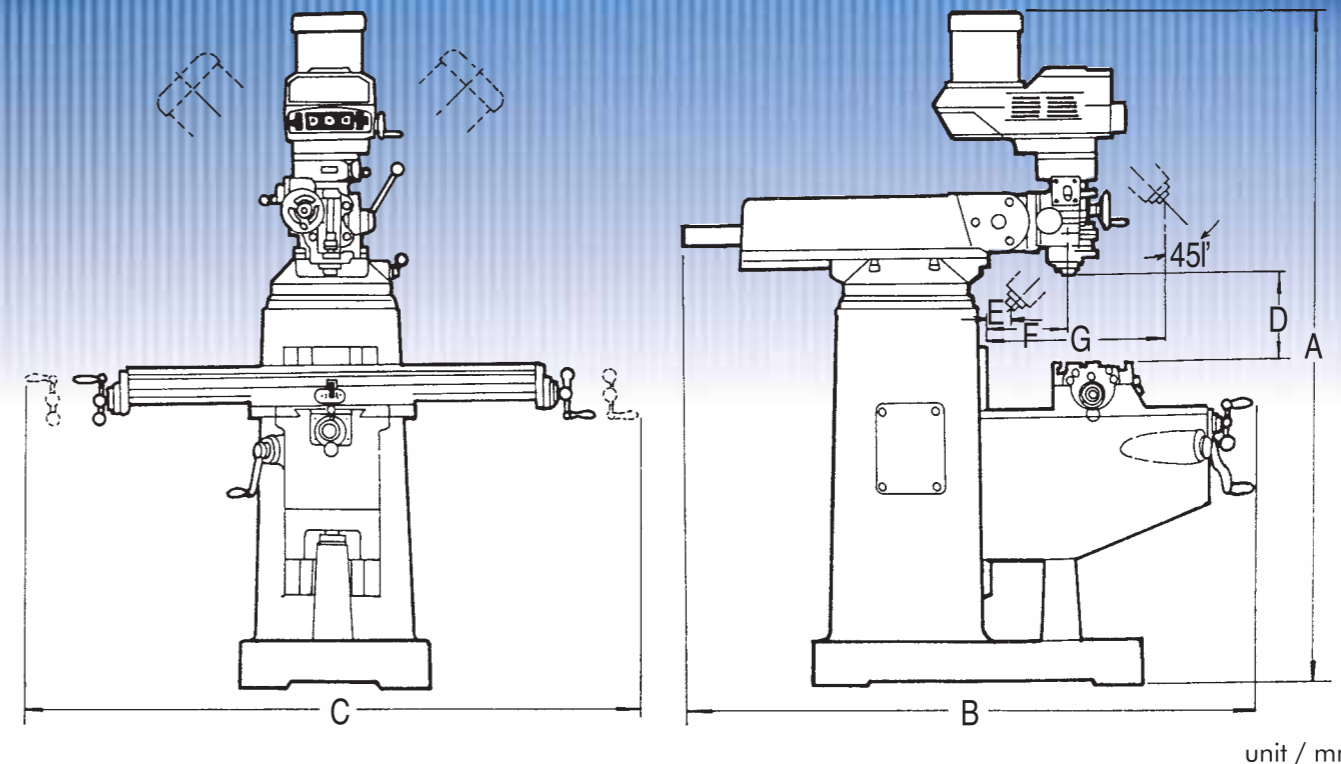

MODEL	1V	2V	3V	4V	6Vi	
A x B x C	2150x1600x1900	2250x1675x2520	2210x1980x2570	2255x2700x1970	2390x1960x2290	
D	MAX	430	435	490	470	445
	MIN	50	80	110	115	85
E	MAX	280	500	480	480	500
	MIN	0	0	0	0	0
F	MAX	465	585	650	740	745
	MIN	115	115	90	185	185
G	MAX	515	645	740	745	775
	MIN	165	175	180	190	215

# STANDARD ACCESSORIES

- All Meehanite Casting Machine Body.
- Worktable Hardened & Ground.
- Chromed X & Y Leadscrews. (except 1V)
- Ground Table T-slots. (except 1V)
- Hardened & Ground Slideways.
- Anti-Rust, Fine-Finish Durable Paint.
- Tools & Tool Box. 1 set.
- Front Chip Guard 1 pc.
- Rear Chip Guard 1 pc.
- Draw Bar 1 pc.
- Manual Lubricator 1 set.

# OPTIONAL ACCESSORIES

- CE/EMC Conformity Machine.
- CSA Electric.
- Air-Powered Draw Bar. (except 1V)
- Electric Powered Draw Bar. (except 1V)
- Power feed unit for X, Y, Z axis.
- Gear-Type feed unit for X, Y, Z axis.
- Ballscrew For X, Y axis. (except 1V)
- Electrical Cabinet.
- Control Panel Box.
- Coolant System.
- Coolant/Chip Tray.
- Halogen Worklight.
- 2 or 3 Axes D.R.O. System.
- Milling Chuck Set.
- Clamping Kit Set.
- 6" or 8" Milling Vise.
- Horizontal Milling Attachment.
- Right Angle Attachment.
- Slotting Head.

## 4BVS

5HP Mechanical Variable Speed Head  
Without Spindle Brake

## SUP4BVS

5HP Inverter Variable Speed Head , Spindle Brake



Machine Shown With Optional Accessories

## SUP4BVS CNC READY

CNC Ready Machine, Prepared With X/Y/Z Motor Mounting Plates,  
Ballscrews Pulleys+Motor Pulleys+Belts, and The Custom made Control  
Panel Box With Switchs Supplied+Empty Electricial Canbinet.



## 6BVS

5HP Mechanical Variable Speed Head, Without Spindle Brake

## SUP6BVS

5HP Inverter Variable Speed Head, Spindle Brake



Machine Shown With Optional Accessories

## SUP8BVS

7.5HP Inverter Variable Speed Head, Spindle Brake



# MACHINE SPECIFICATIONS

unit / mm

ITEM/MODEL	4BVS	SUP4BVS	6BVS	SUP6BVS	SUP8BVS
<b>TABLE</b>					
Table size	10" x 54" (254 x 1370mm)		15" x 60" (380 x 1524mm)		16.75" x 62" (425 x 1575mm)
Table load capacity	800 lbs		1100 lbs		1550 lbs
Number of T-slots	3		3		4
T-slots width	0.63" (16mm)		0.709" (18mm)		0.709" (18mm)
T-slots center distance	2.48" (63mm)		3.15" (80mm)		3.15" (80mm)
Table ways (X Axis)	Dovetail		Dovetail		Dovetail
Bed ways (Y Axis)	Square		Square		Square
Column ways (Z Axis)	Square		Square		Square
<b>TRAVELS</b>					
Longitudinal (X Axis) - Manual	29.53" (750mm)		41.34" (1050mm)		47.24" (1200mm)
Cross (Y Axis) - Manual	17.52" (445mm)		19.69" (500mm)		22.83" (580mm)
Vertical (Z Axis) - Manual	19.29" (490mm)		23.62" (600mm)		23.62" (600mm)
<b>With concertina way covers vertical travel reduce 50 mm</b>					
Quill	5" (127mm)		5" (127mm)		6" (152mm)
Head tilt (left or right)	90°		90°		90°
X/Y axis feeds	0.71-31 (in/min) 18-788 (mm/min)		1.1-43.3 (in/min) 28-1100 (mm/min)		1.1-43.3 (in/min) 28-1100 (mm/min)
Z axis feeds	0.71-31 (in/min) 18-788 (mm/min)		0.71-31 (in/min) 18-788 (mm/min)		0.71-31 (in/min) 18-788 (mm/min)
X/Y axis AC motor	1/2 HP W/-Brake		1 HP W/-Brake		1 HP W/-Brake
X/Y/Z axis AC motor	1/2 HP W/-Brake		1/2 HP W/-Brake		1/2 HP W/-Brake
X/Y/Z Inverter driver	1HP		1HP		1HP
<b>SPINDLE</b>					
Spindle motor	5HP	5HP W/-Brake	5HP	5HP W/-Brake	7.5HP W/-Brake
Inverter drive	Mechanical	5HP	Mechanical	5HP	7.5HP
Low gear range (rpm) 50HZ	55-410	65-590	55-410	65-590	65-590
Low gear range (rpm) 60HZ	70-500	65-590	70-500	65-590	65-590
High gear (rpm)50HZ	470-3550	575-5160	470-3550	575-5160	575-5160
High gear (rpm)60HZ	570-4300	575-5160	570-4300	575-5160	575-5160
Spindle taper	NT 40		NT 40		NT 40
Spindle bearing	CP 4		CP 4		CP 4
Quill feed in/revolution	0.0016/0.003/0.006		0.0016/0.003/0.006		0.0016/0.003/0.006
Quil feed mm/revolution	0.04/0.08/0.15		0.04/0.08/0.15		0.04/0.08/0.15
Quill dia.	4.13" (105mm)		4.13" (105mm)		4.33" (110mm)
<b>CONSTRUCTION</b>					
Width across column ways	11.73" (298mm)		11.73" (298mm)		11.73" (298mm)
Length of saddle on bed	25.98" (660mm)		47.24" (520mm)		53.15" (1350mm)
Width across bed ways	16.53" (420mm)		20.47" (420mm)		22.83" (580mm)
Floor to table surface	36.20" (920mm)		37.00" (940mm)		34.30" (871mm)
Ball pitch (Imperial)	2"		2"		2"
Ball pitch (Metric)	5 mm		5 mm		5 mm
Ball screw dia.	1.26" (32mm)		1.26" (32mm)		1.26" (32mm)
Ball scre class	C7		C7		C7
Halogen work light (Long arm)	24V / 55W		24V / 55W		24V / 55W
Coolant pump	1/8HP-180L		1/8HP-180L		1/8HP-180L
Gross weight	4400 lb (2000 kgs)		6600 lb (3000 kgs)		7260 lb (3300 kgs)

• Above specifications are subject to change without prior notice.

# BED MILL MACHINE DIMENSIONS

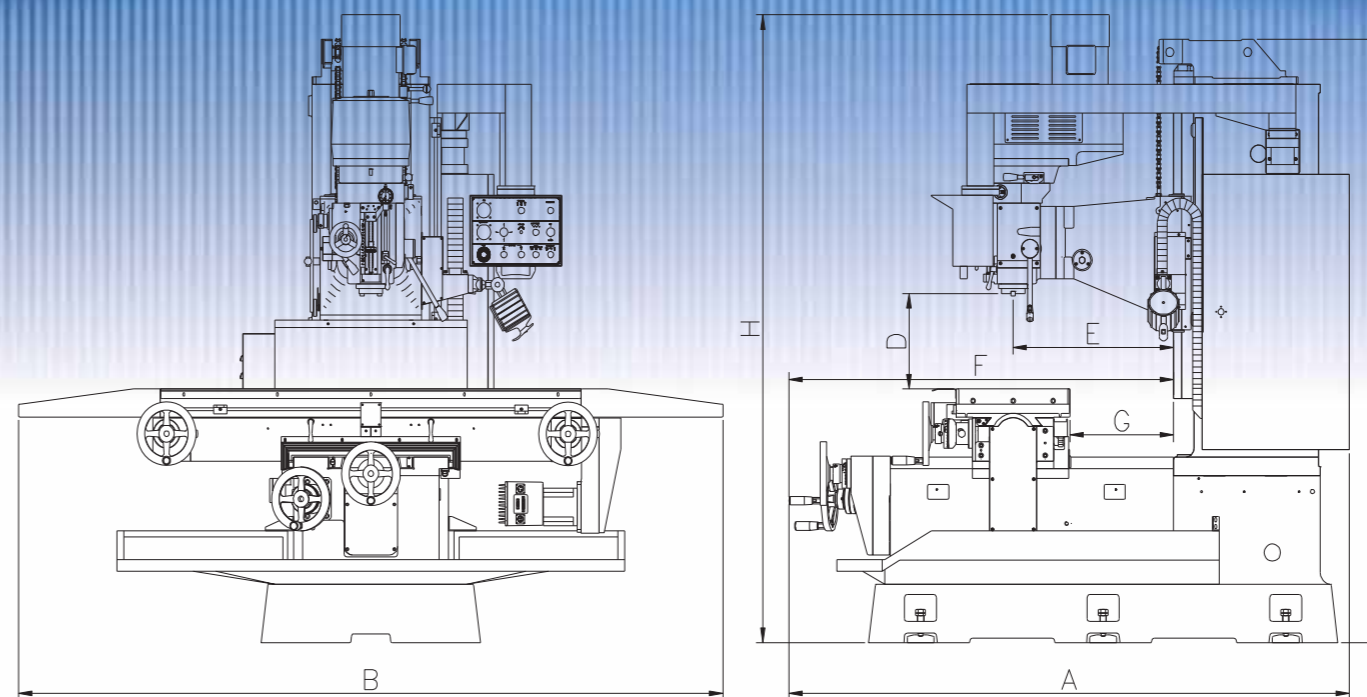

unit / mm

MODEL	4BVS / SUP4BVS	6BVS / SUP6BVS	SUP8BVS
A x B x C	1680x1815x2000	1950x2360x2170	2050x2490x2150
D	MAX	580	700
	MIN	80	100
E	440	520	600
F	1150	1200	1300
G	MAX	530	552
	MIN	80	52
H	2500	2600	2680
NET WEIGHT	2000 kgs	3000 kgs	3300 kgs

## STANDARD ACCESSORIES

- X / Y / Z Brake Motors
- X / Y / Z AC Inverter Drive Control
- X / Y Axes Fitted W/ '-HTD' Belt Drive
- Z Manual Brake
- Quill Feed Dial Indicator
- Electromagnetic Brake on Spindle Motor
- CP4 Abec7 Angular Contact Spindle Bearing
- C7 Double Nut X/Y/Z Ballscrews
- Wear-resistance Flim on Saddle X/Y/Z Ways
- Table Hardened & Ground, T Slots Ground
- 4 Handwheels W/ - Clutch Lever
- X Front Dual Handwheels
- Elec. Box W/-Lockable Main Switch
- Long Arm Halogen Work Light
- Auto Lube W/- Alarm
- Coolant System/Pump
- Heavy Duty Swarf Tray
- Steel Front, Rubbe Rear, Y Way Covers
- Z Axis Concertina Way Covers (SUP Only)
- Meehanite Castings
- Y/Z Square Ways Hardened/Ground
- Tools & Tool Box, Parts List
- Operation Manual, Test & Accuracy Chart

## OPTIONAL ACCESSORIES

- CE/EMC Equipment Including Quill Guard/Cut-out Switch, EMC Filter, CE Approved Contactors, etc...
- CSA Electrics
- Heavy Duty Back Guard
- Table Guard
- Table Guard With Limit Switch
- Coolant/Oil Skimmer
- Quill Guard W/-Cut-out Switch & CSA On/Off Only
- Air Power Drawbar CE
- Transformer 5KVA (For 208V / 240V Or 460V-600V)
- Fagor 3 Axes DRO